



NIGHT OWLS

A CAMP TO GO
FROM THE BC CAMPING COMMITTEE



Copyright © 2019 Girl Guides of Canada-Guides du Canada, British Columbia Council,
107-252 Esplanade Ave W, North Vancouver, British Columbia V7M 0E9

Unless otherwise indicated in the text, reproduction of material is authorized for non-profit Guiding use within Canada, provided that each copy contains full acknowledgment of the source. Any other reproduction, in whole or in part, in any form, or by any means, electronic or mechanical, without prior written consent of the British Columbia Council, is prohibited.



CONTENTS

INTRODUCTION	4
PROGRAM SCHEDULE	5
PROGRAM WORKSHEET	7
SAMPLE NAME TAG	10
NAME	10
TIPS & HINTS	11
Patrol Duties/Chores	11
Designating Boundaries	11
PROGRAM NOTES.....	12
ROUND ROBIN ACTIVITIES.....	13
Station 1 – Basic First Aid	13
Station 2 – Sit-Upons	16
Station 3 – Bags and Bedrolls	17
Station 4 – Fire Safety and Match Lighting	20
Station 5 – Ten Essentials, Hug-A-Tree and Hiking Safety.....	21
GAMES	23
Rainy Day Games – Thanks to Becky's Guiding Resource Centre.....	23
Banana, Banana, Banana Split – Thanks to Guiding With Jewels	24
Caterpillar – Thanks to Guiding With Jewels	24
Puppy and Bone – Thanks to Becky's Guiding Resource Centre	24
Unstructured Free Time	24
MENU & RECIPES	25
GRACES	27
CAMPFIRE.....	28
GUIDES OWN & REFLECTIONS.....	28
KIT LIST.....	30
EVALUATION FORM.....	31

INTRODUCTION

Welcome to Night Owls, a special event for Brownies. We hope the girls and adults will be active, have lots of fun taking their camping skills to a new level and enjoy learning the basic skills and fun of camping.

In this camp package, you will find the program outline for a two-night event and a wide variety of activities, games and crafts to choose from. As well, there are menu and recipe suggestions, a campfire, Guides Own and a kit list. We encourage you to build your camp to suit your season of the year, building or campsite, number of girls and available time. Pick those activities that work the best for you and your girls and remember to be **flexible**. Adapt this package to have fun while learning to camp.

Remember to use the most recent [Safe Guide forms](#) and to have them assessed as appropriate. Be sure to inform your Camping Advisor and District Commissioner of your camping plans, and draw on the resources available to you within your district (Camping, Music, Program Advisers, local trainers, etc.).

Crests order forms are available on the BC Girl Guides website (<https://www.girlguides.ca/WEB/BC/>), and crests are \$1.00 each for units from BC. There is also an evaluation form at the end of this package, and we would love to hear feedback from you regarding this camp. We love receiving pictures, so please send photos from camp (making sure that everyone in them has image releases in iMIS) and feedback to the BC Camping Committee at bc-camping@girlguides.ca.

In this camp, as in every camp, a vast amount of material has been covered and learning has happened. Please, be sure you are adding activities completed to the girl's Girls First program.

The BC Camping Committee has two rules in addition to Safe Guide that we ask you follow at each and every camp:

1. Be a No Trace Camper – Take only pictures, leave only footprints
2. Have FUN!!



PROGRAM SCHEDULE

Please remember although we have provided this schedule, you should remain flexible and adjust it to suit your camp.

Friday

7:00pm	Registration Opening (Campers arrive at camp having eaten dinner.) <ul style="list-style-type: none"> - Divide into program groups - Hand out group nametags - Brownies set up beds
8:00pm	Opening <ul style="list-style-type: none"> - Welcome and introductions (Guiders, First Aider(s), Quartermaster(s)) - Safety (rules, boundaries, etc)
8:15pm	Sing-A-Long and Mug Up
9:00pm	Get ready for bed, bed time story (TTT- teeth, toilet, tuck-in)
9:30pm	Lights Out

Saturday

7:00am	Wake Up <ul style="list-style-type: none"> - Tell Brownies the night before that they can quietly look at books if they are awake before everyone else.
7:30am – 9:15am	Breakfast Lend-a-Hand Duties Hand out packable snacks and fill up water bottles
9:30am – 12:20pm	Round Robin Stations <ul style="list-style-type: none"> - Stations are listed on pages to follow. - First three of five round robin stations (50 min each plus transition time, snack as girls are hungry). - Mix of crafts and games is recommended. - Allow 10 minutes to transition from sites to stations, and between stations
12:30 – 2:00	Lunch Lend-a-Hand Duties Hand out packable snacks and fill up water bottles
2:00 pm – 4:00 pm	Round Robin Stations <ul style="list-style-type: none"> - Last two of five stations (50 min each plus transition time) - Snack at the end of stations
4:00 – 5:00	Games

5:00 – 6:00	Free time <ul style="list-style-type: none"> - You may want to have some veggie sticks out, that the Brownies can snack on while they wait for dinner. For Brownies who may need more structure, you can have a few colouring pages, easy self-directed crafts or a quiet game.
6:00 – 7:30	Dinner Lend-a-Hand Duties
7:30	Campfire
8:30	Mug Up
9:00	Get ready for bed, bed time story (TTT- teeth, toilet, tuck-in)
9:30	Lights Out

Sunday

7:00am	Brownies allowed to get up; pack up before breakfast <ul style="list-style-type: none"> - Have a craft or quiet activity ready for Brownies who are ready quickly
8:00am	Breakfast Lend a Hand Duties
9:30am	Games, Scavenger Hunt, and/or outdoor clean-up for Brownies while Guiders clean and pack up for check-out
10:00am	Closing ceremonies, Guides Own, and Group Photo
10:30am	Depart camp
	It is possible to extend your camp to the afternoon. You will need to provide lunch and more activities. Choose from those provided.

PROGRAM WORKSHEET

Friday

Time	Activity	Responsible Guider	Equipment Needed
7:00pm	Greet Brownies		
	Divide into program groups		
	Hand out group nametags		
	Brownies set up beds		
8:00pm	Opening		
8:15pm	Sing along & Mug Up		
9:00pm	Bed		

Saturday

Time	Activity	Responsible Guider	Equipment Needed
7:00am	Wake up		
7:30am	Breakfast		
8:30am	Duties		
9:00am	Hand out snacks		
9:30am	Station 1		

Time	Activity	Responsible Guider	Equipment Needed
10:30am	Station 2		
	Snack		
11:30	Station 3		
12:30pm	Lunch		
1:15pm	Duties		
1:45am	Hand out snacks		
2:00	Station 4		
3:00	Station 5		
	Snack		
4:00pm	Games		
5:00pm	Free Time		
6:00pm	Dinner		
7:00pm	Duties		
7:30pm	Campfire		
8:30pm	Mug Up		
9:00pm	Bed		

Sunday

Time	Activity	Responsible Guider	Equipment Needed
7:00am	Pack up		
8:00am	Breakfast		
9:30am	Games, outdoor clean-up		
10:00am	Closing, Guides Own		
10:30am	Depart camp		



SAMPLE NAME TAG

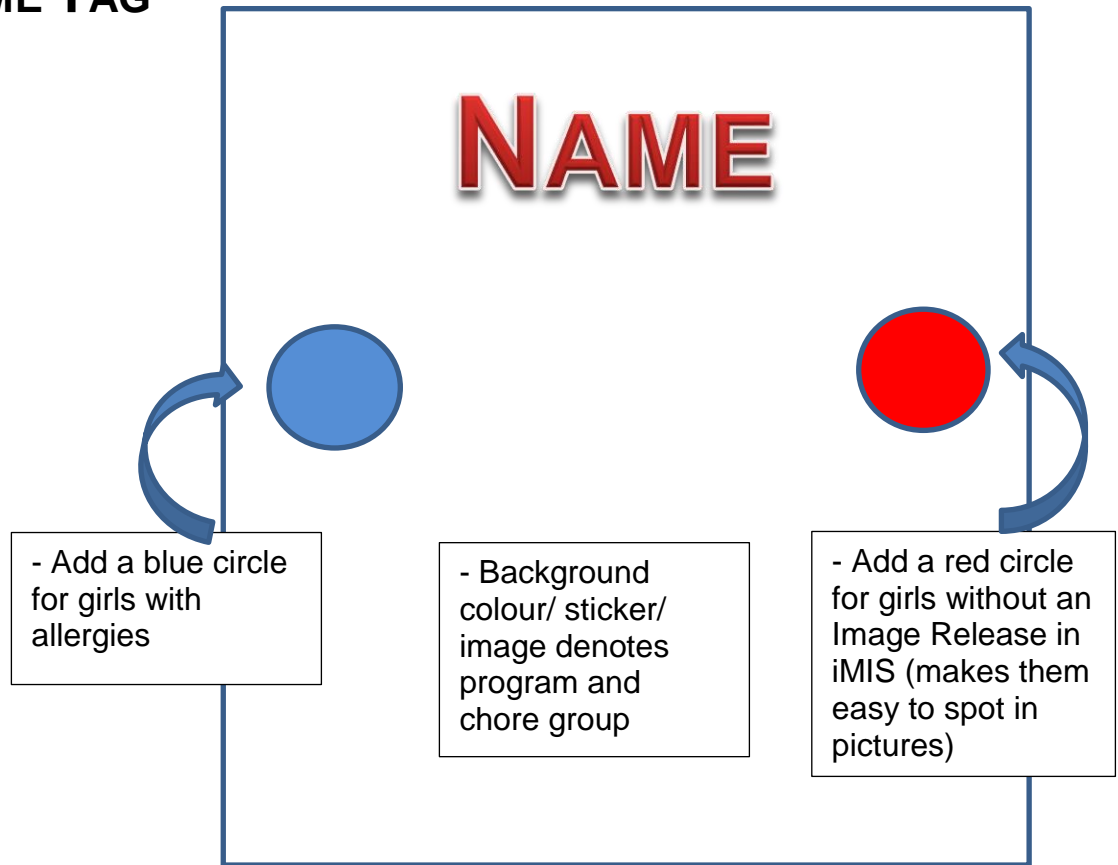

TIPS & HINTS

Patrol Duties/Chores

Lend-A-Hand Duties should include: helping with meal preparation, setting and clearing the table, dishes, sweeping the floors, tidying washrooms, etc. You know your girls and your camp location best, so your team can decide how and where the girls can be most helpful.

NOTE: Often the girls aren't terribly helpful, but it is important for them to get used to helping with chores at camp. Try to find jobs at each station that the girls can help with: washing and cutting fruit, flipping one pancake, ripping lettuce for salad are all great ways the girls can help in the kitchen.

Sample Chore Chart

Time	Meal prep & setting tables	Wiping tables, sweeping floors	Lats	Dishes
Saturday Breakfast	Group A	Group B	Group C	Group D
Saturday Lunch	Group D	Group A	Group B	Group C
Saturday Dinner	Group C	Group D	Group A	Group B
Sunday Breakfast	Group B	Group C	Group D	Group A

Designating Boundaries

For Brownies you can use "Mr. Happy" and "Mr. Grumpy" faces cut out of fluorescent poster board. Use a plate to trace then cut out 9 per page. Use bright pink and lime green colours. Draw happy faces on the pink ones and grumpy faces on the green ones then post them around the camp to establish boundaries. If you have Guides or Pathfinders attending the camp with Brownies they love to put these up for you. At the end of camp take them down and give them to the girls to take home.



PROGRAM NOTES

Name tags can be made in advance or made/decorated at camp. You can use name tags to help identify girls with an Image Release “No”, food allergies, or other health concerns. There is a sample name tag on page 9.

Scarves

Cut inexpensive cotton into squares for scarves. Stitch or cut the edges with pinking shears to prevent fraying. Have a different colour for each Circle. Girls may like to sign and date their scarf as a keepsake!

Program group suggestions (have fun with it):

- Squirrels
- Owls
- Bears
- Racoons
- Foxes
- Bats

Sing along/campfire: Friday evening sing-along is an informal time to sing the girls' favourite songs and perhaps learn some new ones for Saturday's campfire.

Designed for Brownies: This two-night camp has been created with Brownies in mind. If your situation requires it, you can take portions of the program and adapt it for a one-night camp or day camp. Feel free to use other age-appropriate activities related to the theme or adapt Unit favourites to fit the theme.

To use this camp for Guides: While most of the activities would be suitable for girls of Guide age, you may want to make the activities more challenging. If you plan to do patrol cooking allow more time for preparation, cooking, eating and clean-up!

ROUND ROBIN ACTIVITIES

The activities can be mixed and matched as needed. Fifty minutes has been allowed for each station; and each station can be made up of several activities.

Station 1 – Basic First Aid

Band-Aid Tag – Thanks to Guiding with Jewels

- Each girl has 2 Band-Aids (her hands). When tagged, she now has germs on her. She covers the tagged spot with a Band-Aid (her hand).
- If she has no more Band-Aids, then she has to freeze in her spot.
- Two girls are it and must try to tag the others. Switch the girls every few minutes.
- A girl can rejoin the game if another girl administers first aid by tapping the girl on the head.

Define An Emergency – From Guides Ontario Emergency Preparedness

Use the list of emergency and nonemergency situations below to test the girls' ability to identify an emergency. Tell them you are going to read a list of emergency and non-emergency situations. If they think it is an emergency they should move to one end of the room. If they do not think it is an emergency they should move to the other end of the room. Confirm whether each situation is an emergency or not.

1. I lost my bike.
2. My neighbour's house is on fire.
3. My television won't work.
4. A person fell in the pool and he can't swim.
5. There is a forest fire in my neighbourhood.
6. My cat is lost.
7. The roads in my town are flooded.
8. There has been a car crash.
9. I have to go to school tomorrow.
10. My mom/dad/grandma/grandpa fell and can't get up

Care for a Stuffedie

Materials: a variety of bandaids, slings, splints

Each girl has a stuffed toy or a doll. You tell a story about what has happened to the toy and the girls "fix" it.

Personal First Aid Kits

Materials: a variety of bandaids (2 of each kind per girl), 4 wet wipes per girl (non-alcohol), small dollar-store container or pouch to store everything

Each girl puts together a small first aid kit that they can keep in their school bag, or bring to camp and Brownie activities with them.

Make It Stick – Bandage Skills

Materials:

- Washable markers (a variety to share)
- Damp cloths (1 per 2 people)
- Band-aids (2 per person; latex free)

1. As a group, talk about: When was the last time you got hurt? Who took care of you? Are there times when you could take care of yourself or your friends when they get hurt?
2. Draw a circle on your skin with a washable marker. Imagine this is a small cut you got when you were playing outside.
3. Wash away the circle scrape with the clean damp cloth. Wait for the skin to dry.
4. Open the band-aid wrapper. Try not to touch the gauze part of the band-aid when you're taking off the wrapper.
5. Touch the gauze to the cut area and stick the sides of band-aid to your skin.
6. If you want, try it again and put a band-aid on your friend or Guider.



Red Light Green Light – Thanks to Becky's Guiding Resource Centre

To Play: If the question is right or the girls feel they should say yes, they take a step forward. If the answer is no, or it is something they shouldn't do, they don't move. If they get the wrong answer, they go back to the beginning.

Suggested questions: (please feel free to add any of your own)

1. When someone first starts choking, you should stand by and encourage them to cough. – Yes
2. The first thing you do for an unconscious person is to check to see if they are breathing. – No (You go for help.)
3. If someone is cold you should put them in a hot bath to warm them up. – No (a lukewarm bath)
4. To treat frostbite, you should get out of the cold and warm up the affected area with body heat. – Yes
5. You lose the most heat from your head. – Yes
6. When we are at camp another Brownie can put a Band-Aid on your cut. - No (A Guider must do this).
7. You should clean animal bites with soap and warm water. – Yes
8. You should always pop a blister. – No (Blisters are nature's Band-Aids.)
9. As Brownies we all have to bring health forms to camp to make leaders aware of any allergies or medical conditions that we have. - Yes
10. To treat a small cut, clean it with soap and water and apply a Band-Aid. - Yes
11. To treat a sunburn, you should apply an after sun lotion or take a cool bath. – Yes

12. When cleaning a wound, always wipe around and across the edges of the wound. – No (Wipe away from the edges of the wound to keep the dirt out of it.)
13. To prevent heat exhaustion drink plenty of water and wear a hat. – Yes
14. Some people have life threatening allergies to spider and insect bites and use an EpiPen if they get bitten. – Yes
15. If someone has fallen down and hit their head it is okay to tell them to get up and run around some more. - No (Tell them to stay where they are and call a Guider)
16. For a nose bleed the right treatment is to your head back, lifting your nose to the air - No (with a Guiders help leave tilt your head slightly forward and pinch the soft part of your nose for 10 minutes)
17. In case of an emergency you should call 911. - Yes
18. As soon as you reach someone at 911 you can hang up the phone. - No (Stay on the line)
19. There are some plants that should not be touched because they can cause you to sting or itch. - Yes
20. If someone has a small burn cool water will help it feel better. - Yes

First Aid Relay

Materials: a bandaid for each girl

To Play:

- Have girls divide up into two lines. Each girl is given a band-aid.
- The girl at the front of the line takes about 10 large steps forward and turns around to face the others in the line, she is the starter.
- The Guider (or extra girl) can be the caller. She says Go, Arm or Leg or Elbow
- When “GO, arm!” is said, the first girl in line runs up to the starter, hold out her arm and gets a band-aid stuck on it. She then becomes the starter, and the first starter goes to the end of the line.
- Relay continues until all girls have a band-aid stuck on them.
- After game, have them get the person who put the bandaid on them to sign the bandaid.

Note: This game can also be done using a Stuffie instead of the girls.



Station 2 – Sit-Upons

Materials: Scissors, duct tape, one waterproof reusable shopping bag per person, one stack of newspaper per person

Instructions:

1. Fill a reusable shopping bag with newspaper. Make it as thick as you like.



2. Choose matching duct tape for the edges of the bag. Cut the duct tape to the correct length for each side.

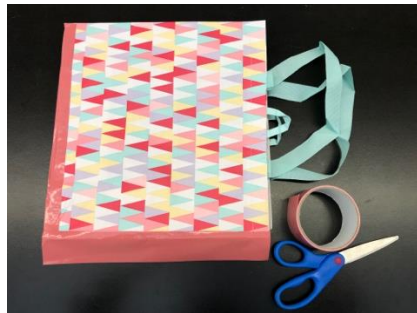

3. Completely seal the edges of the bag with duct tape. Make sure that the handles of the bag are kept free so that the handles can be used.

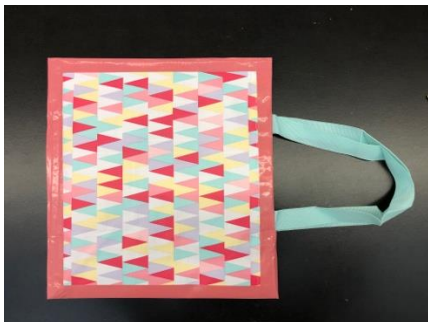

Station 3 – Bags and Bedrolls

Stay Warm and Dry!

Materials:

- Mini pairs of pants cut from a variety of fabrics (fleece, heavy cotton, yoga pant, cotton legging, flannel pajamas)
- Bowl of water



1. Give each girl a pair of pants and let them know that you will be calling them up during the story
2. As you tell the story, invite the girls up and dip the pants into the bowl of water.
3. At the end of the story, compare which pants are still wet, which ones would stay warm when wet, and which ones are already dry.

The story:

The Brownies were so excited to go outside, but first, they had to get dressed. Two girls put on their fleece pants, two put on their cozy sweat pants, two put on yoga pants, two put on leggings, and two couldn't find their pants and wore their pajamas. It had been raining overnight, so the grass was wet and there were puddles everywhere.

The girls decided to play tag, so they ran outside on the wet grass. The girls in the pajama pants (invite them to come up) got cold, partly because their pants weren't very warm, but also because the cuffs were dragging through the wet grass. The water started wicking up the pant legs, making the girls even colder.

The girls in the sweat pants (invite them to come up) forgot to put on their rain boots, so the cuffs of their pants also got wet when they accidentally stepped in a puddle, and soon, their pant legs were wet, heavy and cold. (You could say that this also happens with jeans).

The other girls decided it was more fun to jump in the puddles with their boots and make big splashes, and soon their pants were wet too (invite everyone else to come up).

The girls in the leggings felt really cold because the wet fabric was right against their skin, and wasn't drying. Some other girls were wearing yoga pants, and although their pants were also up against their skin, they didn't feel as cold. The girls wearing the fleece pants noticed something funny about their pants – they jumped in puddles too, but their pants didn't look as wet as the others.

Who has the wettest and coldest pants?

Obstacle Course While Carrying Gear.

Materials:

- benches, logs, trees, chairs steps, etc. to set up a course
 - 1 pack with a bedroll for each team (this can be as big and awkward as needed)
 - shoes and/or dishes to tie to the pack (optional)
1. Set up the obstacle course before the girls arrive.
 2. Either run this as a relay or as a team building exercise.
 3. As a team building activity, let the team of girls decide the best way to get one girl through the course without losing any of her gear.
 4. This can be made more difficult by having very large bedrolls, incorrectly packed and/or shoes and dishes hanging off the pack.
 5. Be sure to talk about what would have worked better at the end.

Which Clothes Fun-Run

Materials: Number of clothing items for a variety of seasons

1. Depending on the number of girls this can be run as a relay or as individuals.
2. Leader lines the girls up at one end of the play area. She calls a season or an activity such as, "hot summer hike".
3. The girls run to the pile of clothes and put on one item that would be suitable.
4. Continue until all the girls have participated or until all the items are taken.
5. Take a picture of the girls in their seasonal clothing.



Edible_Bedroll

Materials:

- Wrapper from fruit leather = tarp
 - Thin fruit leather = sleeping pad
 - 1/3 of Fruit Roll Up = sleeping bag
 - 1 Mini Marshmallow = pillow
 - 1 Gummie Bear = teddy bear
 - Lace Licorice = rope
1. Carefully open "Fruit to Go" wrapper (tarp) along center back seam and layer the next four items in center of wrapper. "Fruit to Go" (sleeping pad) "Fruit Roll Up" (sleeping bag) "Marshmallow"

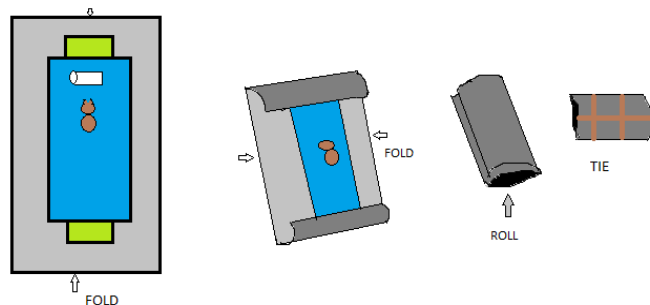

- (pillow) "Gummie Bear" (teddy bear)
2. Fold excess tarp over sleeping bag at top and bottom.
 3. Fold sides of tarp in, overlapping to cover sleeping bag.
 4. Roll entire package tightly and secure with elastic band.
 5. Tie with "Lace Licorice" (rope). Although a Packer's Knot is the best way to secure the bedroll, let the Brownies use any knot.

Bedroll Hat Craft

Materials:

- Felt
 - craft foam
 - clear plastic
 - Mini hair elastics or small piece of string
 - safety pin
1. Cut the pieces for this ahead of time.
 2. From the felt, cut rectangles about 1 x 2½ inches.
 3. Cut slightly larger pieces of the craft foam, and slightly larger pieces from the plastic.
 4. Lay out the plastic.
 5. Layer the plastic, foam then felt.
 6. Fold the bottom end of plastic over the "sleeping bag" and "foamie".
 7. Fold in the sides of the plastic.
 8. Roll from the bottom up.
 9. Place the mini elastics around the bedroll.
 10. Girls can practice tying the string once the elastics are holding it all together.
 11. Add the pin.

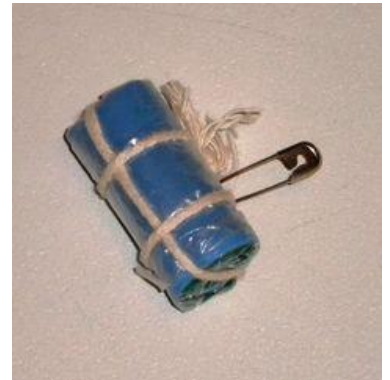

Bed roll game "Cootie Bedroll – Thanks to Becky's Guiding Resource Centre

Materials for each team: a dice (big ones are best) 1 spot = ground sheet, 2 = sleeping bag, 3 = pjs and toque, 4 = extra blanket/pillow, 5 = roll up 6 = rope ad tie-off

Demonstrate a proper bedroll first. Split the group into teams.

1. The girls work as a team and roll the dice. They cannot do a step in bedroll prep until the spot has been rolled i.e. the team MUST roll a one first, they cannot do the next step until a two is rolled, etc.
2. This makes for lots of jumping and screaming when a few teams are trying to win.
3. Once the winner is established and acknowledged, it is time to test the bedrolls.
4. Form a large circle. Pass or throw the bedrolls around the circle to see which patrol has done the best job of preparing a tight, well-wrapped bedroll.
5. Prizes can be awarded and shared.

Station 4 – Fire Safety and Match Lighting

Fire Safety In or Out

Materials:

- A piece of rope long enough to make a circle on the ground around your group of Brownies

To Play: If the question is right or the girls feel they should say yes, they step outside of the circle. If the answer is no, or it is something they shouldn't do, they step into the circle. If they get the wrong answer, you can tell them the correct answer and why, and continue with the game.

Suggested questions: (please feel free to add any of your own)

1. The campfire pit is the stone ring around the fire, as well as the space between the benches and the stone ring. – Yes
2. It's OK to run and play games around a campfire pit. – No (you could fall and burn/hurt yourself)
3. When singing an action song, it's OK to get really close to the stone ring around the fire – No (stay behind the benches or logs that people sit on)
4. A girl can be in charge of the campfire, and add wood to the fire. – Yes (with instruction and supervision)
5. It's OK to leave a campfire unattended to go get something you forgot. – No (you should always have someone, preferably an adult, attending the fire)
6. We should have water or sand buckets next to the fire – Yes (to put it out)
7. If a spark lands on our clothing, we should jump up, scream and run around – No (calmly fluff the spark off your clothing and onto the ground)
8. A campfire needs to be really really big to keep everyone warm – No (everyone should dress warmly when they come to campfire, and the fire should be kept at a manageable size)
9. Your hair should be tied back, the strings on your hoodie or coat hood should be tucked in, and no loose clothing around a campfire – Yes
10. A campfire is out when the ashes are cold, and there is no more smoke when you pour water or stir the ashes – Yes

Fire Starters

Materials:

- Toilet paper tubes, dryer lint: Loosely stuff dryer lint into an empty toilet paper roll
- Corrugated cardboard, thin birthday candles: Cut cardboard into small card-sized pieces. Push candles into the holes on either side of the cardboard.

Match Lighting and Mini S'Mores

Materials:

- Foil plates filled with ½" water
- small packages of matches or matchbooks
- tealight candles
- toothpicks or skewers
- mini marshmallows
- Teddy Grahams
- chocolate chips



Review safety concerns from Fire Safety In or Out game, and make sure all Brownies have their hair tied back, and no clothing or parts of clothing are dangling loose. Review proper way to hold a lit match (like a lollipop, flame up and stick down).

Set up Brownies at tables or along benches, and ensure that they have enough space between each other. Each Brownie's station should have a pie plate with water in it, a small package of matches, three toothpicks, three mini marshmallows, three chocolate chips, and six Teddy Grahams. Brownies light matches over their plate filled with water (they can drop the match into the plate of water if they panic), and attempt to light their tealight. Once they succeed, they can roast their mini marshmallows over the fire with the toothpicks, and then assemble their mini s'more.

Station 5 – Ten Essentials, Hug-A-Tree and Hiking Safety

Ten Essentials Kim's Game

Materials:

- Flashlight with spare batteries
- matches and tealight candle in a waterproof bag or container
- whistle
- extra food and water
- extra clothing
- map (don't rely only on your GPS or phone)
- small first aid kit
- orange garbage bag and silver emergency blanket (or combo blanket that is orange on the outside and silver on the inside)
- pocket knife
- sun protection (glasses, sunscreen, hat)
- Small towel large enough to cover all items when they are placed on the table

Review all items with Brownies, lay out on table and cover all items with the towel. Ask Brownies to name all the Ten Essentials and their use.

Hug-A-Tree and Hiking Safety – Thanks to AdventureSmart’s Hug-A-Tree and Survive

Hug-a-Tree and Survive is an AdventureSmart program that helps lost children survive in the woods. It teaches children how not to become lost in the woods, and what to do should they become lost.

If a child should become lost in the woods, hugging a tree can help them stay safe, and be found. Staying near a tree offers some protection from the elements, and keeps lost children in the same place, which makes it easier for searchers to find them.

To Play: Plan a short hike around your campsite or nearby trails with the Brownies, but before you leave, review the Hug-A-Tree and Survive four key rules to keeping children safe:



1. Tell an adult where you are going.

Always tell your parents, or another trusted adult where you are going,

who you are going with, and when you will be back. You can do this in person, over the phone, through a text message, or by leaving a note in a place they will see it.

2. If you are lost, “Hug-A-Tree” and stay put.

A tree can help protect you from the elements while you’re outdoors, and most importantly, keep you in one place. Depending on where you are, there may not always be a tree. Perhaps your “tree” can be a large rock or bench at a park, or a sales counter at a mall. No matter what your landmark is, it is important to stay put, in order to stay safe.

3. Keep warm and dry.

Temperatures change throughout the day, and can drop at night. Even if you are warm during the day, keep your jacket handy for night time. If you get cold, put on an extra layer, pull up your hood or put on your hat if you have one, tuck your shirt in, tuck pant legs into your socks, and zip up your jacket. You can also keep warm by building a nest to keep you off the ground, or by using an emergency shelter.

4. Help searchers find you by answering their calls.

Whether searchers are parents, police officers, or SAR volunteers, remember they just want to get you home safely. Answer back to their calls by making noise and signaling, so you can be heard and seen. Make sure to leave lots of footprints and clues, so searchers can follow your tracks to find you.

GAMES

Rainy Day Games – Thanks to Becky's Guiding Resource Centre

The best rainy day activity is to get out and enjoy it!

Before venturing out on a rainy day some ground work must have taken place. Girls should be aware of different weather types and how to dress for each event. Proper rain boots, coats and hats must be worn (or brought to camp). You must also educate the girls that they should never venture outside if there is a threat of a thunderstorm. This would also be a good time to discuss where it is safe to be during an electrical storm.

Do you realize how many girls have never been out in the rain except to run from the car to the house? If they are dressed properly there is nothing more exciting than watching and sharing the excitement of the girls in their first rainy day outing.

Catching Raindrops: Have a variety of different sized containers and have the girls go out and fill them with rain drops. Have containers with narrow mouths (pill bottles) and wider mouthed ones (drinking glasses), which is easier to catch them in? Which fills faster?

Mud Pies

This old standby has been passed down through the generations and is just as popular today. After finding the perfect mud puddle girls can find sticks, leaves, pine cones and other available artistic tools to create a “mud” masterpiece. They can also be given a piece of newsprint and they can use the mud like a finger paint. Messy but fun. (Have a basin of warm water available for washing up).

Puddle Jumping

Have the girls go out and see if they can jump over the puddles. Make sure they are dressed properly (rain pants and boots), as sometimes they think they can jump further than they can and end up in the puddle. As long as they have dry clothes or are ready to go home this should not create too much of a problem. Parents should be warned ahead of time to expect a soggy child.

Water Tag

Using sponges, the person who is it must tag the others by throwing a wet sponge. This can be done in swim suits if weather permits.

Worm Rescue

During the rain worms get stuck in puddles or on the surface. Rescue these worms by putting them carefully in a dark drier place such as under a leaf or in the bush.

Banana, Banana, Banana Split – Thanks to Guiding With Jewels

This is a variation of "Duck Duck Goose"

To Play: Have girls sit in a circle. Choose one child to be "it". Have this girl walk around the circle, tapping each child lightly on the head, saying "Banana" every time she taps someone. Finally, the girl taps someone on the head and says "Banana Split" and then splits, running around the circle as fast as he can. The person who she tapped on the head and said "Banana Split" stands up and chases him around the circle in the opposite direction. The goal is to be the first to sit in the now open spot in the circle. Whoever sits in the spot first, remains there and the other child continues the game by walking around the circle, tapping heads, and saying "Banana, Banana, Banana Split!".

Caterpillar – Thanks to Guiding With Jewels

To Play: Divide the girls into teams 3-5 girls each.

At the start line have the girls sit down with their legs wrapped around the waist of the girl in front of them. This forms the caterpillar.

With the girls attached as a team, the Guider yells go.

The girls move together as a unit by using their arms by their sides and lifting and moving their bottoms. The teams race to a designated line or spot. At the line, the girls let go of their link to reform their caterpillar with the girls in the opposite order.

The teams continue racing back to the start line.

Puppy and Bone – Thanks to Becky's Guiding Resource Centre

Materials: A blind fold and a 'bone'

To Play: The children sit in a semicircle facing one child who is the puppy. The puppy wears a blind fold and the 'bone' is on the floor in front of her. A 'thief' is chosen by pointing so as not to let the puppy know which direction the thief is coming from to steal her 'bone'. The thief tries to steal the bone from the puppy without the puppy hearing her. (The rest of the group must sit quietly while she tries). The puppy listens, and points in the direction of the thief and barks, if she hears anything. If she catches the thief by pointing at her, the thief has failed and has to go back into the semi-circle. If the thief succeeds in stealing the 'bone' then she becomes the puppy and the puppy joins the circle for the next round.

Unstructured Free Time

Provide a variety of themed options such as blow-up beach balls, skipping ropes, hula hoops, books, quiet games, colouring sheets or puzzles that do not require supervision. Some girls may prefer to sit and talk quietly.

MENU & RECIPES

Friday Mug Up	Hot apple cider, and hot chocolate Bread Cheese Pizza
Saturday Breakfast	Pancakes, fruit, bacon or sausage Water, milk, juice
Saturday Snack	Cheese Sticks Water Bottles brought to camp
Saturday Lunch	Milk, Juice, Hot Chocolate, Water Taco Buffet Taco shells or nacho chips Cooked ground beef (add taco seasoning if desired) Refried beans (optional) Sour Cream Shredded Monterey Jack cheese Shredded lettuce Diced tomatoes Salsa Allow Brownies to choose the items they want on their tacos.
Saturday snack	Water (from bottles they all brought to camp) Cookies or Granola Bars
Saturday Dinner	Homemade Baked Mac & Cheese Serves 6-8 <input type="checkbox"/> 1/2 pound elbow macaroni <input type="checkbox"/> 3 tablespoons butter <input type="checkbox"/> 3 tablespoons flour <input type="checkbox"/> 3 cups milk 1/2 cup yellow onion, finely diced <input type="checkbox"/> 12 ounces sharp cheddar, shredded <input type="checkbox"/> 1 teaspoon kosher salt <input type="checkbox"/> Fresh black pepper Topping: <input type="checkbox"/> 3 tablespoons butter <input type="checkbox"/> 1 cup panko bread crumbs 1. Preheat oven to 350 degrees F. 2. In a large pot of boiling, salted water cook the pasta to al dente. 3. While the pasta is cooking, in a separate pot, melt the butter. Whisk in the flour and keep it moving for about five minutes. Make sure it's free of lumps. Stir in the milk and onion. Simmer for ten minutes.

	<p>4. Stir in 3/4 of the cheese. Season with salt and pepper. Fold the macaroni into the mix and pour into a 2-quart casserole dish. Top with remaining cheese.</p> <p>Melt the butter in a sauté pan and toss the bread crumbs to coat. Top the macaroni with the bread crumbs. Bake for 30 minutes. Remove from oven and rest for five minutes before serving.</p> <p>S'more Casserole Ingredients:</p> <ul style="list-style-type: none"> <input type="checkbox"/> 9 Honey Grahams crackers (break in half to create 18 squares) <input type="checkbox"/> 36 Marshmallows, cut crosswise in half, divided <input type="checkbox"/> 4 Chocolate Bars, (1.55 oz. each), chopped <p>Instructions:</p> <ol style="list-style-type: none"> 1. Heat oven to 350°F. 2. Place 9 graham squares in single layer on bottom of 8-inch square pan; top with 36 marshmallow halves. Sprinkle with chopped chocolate. Cover with remaining graham squares. 3. Top with remaining marshmallow halves, cut sides down. 4. Bake 9 to 11 min. or until marshmallows are puffed and golden brown. Let stand 5 min. before serving. Cut into 18 squares
Saturday Mug Up	Cheese and Crackers (add meat if desired)
Sunday Breakfast	<p>Water, milk, juice Yogurt Muffins Fruit of some sort Any other leftovers that you may have can be given as an option at this time.</p>

GRACES

Singing a grace before a meal is a tradition that has lost popularity over the years, but it is still nice to thank those responsible for your food before eating it. Singing grace doesn't have to be involved in religion at all, try some of these out for example:

Modified Superman Grace (to the tune of the Superman theme)

Thank the coook, for making us food,
Thank the coook, for making us food,
For the food we eat, and the friends we meet,
Thanks the coook, for making us food
Looks great!

Modified Adams Family Grace (to the tune of the Adams Family theme song)

Da duh da duh <snap><snap>
Da duh da duh <snap><snap>
Da duh da duh da duh da duh da duh da duh <snap> <snap>
We're thirsty and we're hungry
The food looks mighty yummy
We want some in our tummies
And so we thank the cook
Da duh da duh <snap><snap>
Da duh da duh <snap><snap>
Da duh da duh da duh da duh da duh da duh <snap> <snap>

Fork Knife Spoon Spatula

I'm a fork, knife, spoon, spatula
Cha Cha Cha

I'm a fork, knife, spoon, spatula
Cha Cha Cha

I'm a fork, knife, spoon, I'm a spoon,
knife fork, I'm a fork, knife, spoon,
spatula

Cha Cha Cha

Actions: put your arms above your head and mimic the shapes of a knife, fork, spoon and spatula, and wave your arms back and forth for the Cha Cha Cha

CAMPFIRE

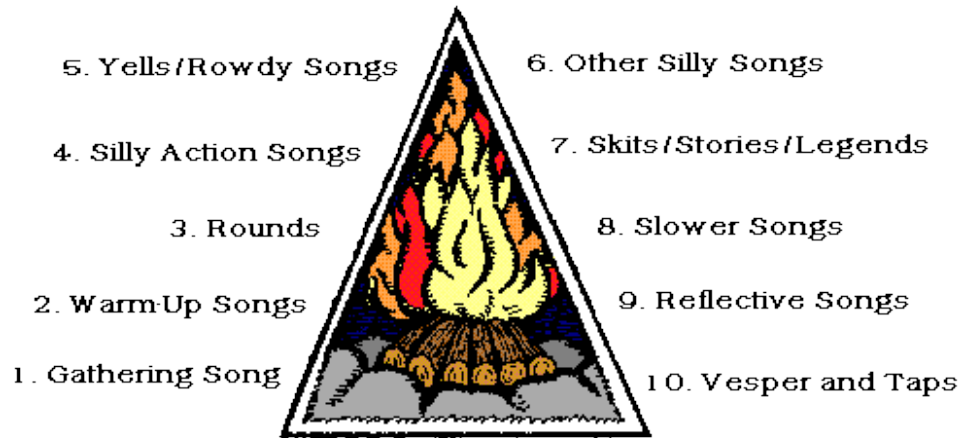

GUIDES OWN & REFLECTIONS

Guide's Own is a special ceremony. It can be used at a camp or any event for personal reflection. It can also be used as a time to give thanks for all we have and our special guiding friends. Guide's Own can be adapted for use with girls of all ages.

A Guide's Own ceremony can be as simple or as complex as you would like to make it – but keep in mind the age of your girls. Also keep in mind the dynamics of your group. Some are much more introspective than others. As the girls get older this is an activity that they can participate in and eventually plan, similar to a campfire.

A Guide's Own can consist of a quiet time, some reflective poems depicting the theme of your camp, a reading of some sort, a song, a short story, or any combination of these.

Simple Thank You To Camp

Ask the campers, as they are helping to pack and clean up, to pick up a rock, twig, or other piece of nature (not living) that is special to them. At your Guide's Own ceremony, ask the campers to come forward, one at a time, and place their rock/twig/etc. in the middle of the circle, and think of something at camp that they are thankful for or they will take away from camp. Campers don't need to share what it is they are thinking of or thankful for; it can be a silent reflection of camp, and a thank you to the camp itself.

A Star and a Wish

This is a good one to use for Brownies since it involves the girls but in a relatively easy way. Each girl and adult takes a turn to say one thing they really liked about the camp (the star) and something that they might not have liked so much or something that they would have liked to do but didn't or something similar to that (the wish). You can incorporate that into the closing and not have a formal Guide's Own scheduled for a separate time.



Guider Equipment List

Items not listed under Crafts, Games or Activities. Check with the camp to see what is provided.

- Tarps, blankets or tables to do crafts on
- Extra blankets for “cold” girls
- First Aid kit
- Whistle
- Watch or clock
- Camera for group photo & other pictures
- Camp Crests (Optional)
- Safe Guide forms: Girls' and Leaders' Health forms (H.1 & H.2), SG.1, SG.2, SG.3, SG.4, H.3, H.4, INS.01
- Available phone if not provided (cell phone)
- Camp menus & food
- Camp tools- hatchet if needed for campfire, shovel for dirt for campfire safety
- Marshmallow sticks, if desired
- Matches, lighter, newspaper (for starting a fire)
- Duct tape
- Cooler
- Camp stove with extra fuel (propane canister if small or white gas if using this type of stove)
- Lantern with necessary hoses
- Cooking utensils & cookware

Suggested items: pots, fry pan, can opener, knives, spoons, spatula, juice jug, water jug, bowls, coffee pot, kettle, pot holder, cutting boards, grater, measuring cups/spoons, toaster

Other kitchen items: coffee, salt, pepper, baking soda (in case of grease fires), tin foil, paper towels, kitchen towel, wipes, non-stick cooking spray or oil, tablecloths, napkins, rubber gloves, garbage bags, food handling gloves, zip-lock bags, rope for clothes line & clothes pins

Dish washing – 3 pans, biodegradable soap, clothes and towels, bleach, scrubbies,

- Hand sanitizer if using biffies – hand soap if not
- Water jug
- Buckets, - water, fire safety

KIT LIST



BED ROLL:

- 1 warm sleeping bag
- 1 sleeping mat – nothing that needs a pump, please!
- 1 small pillow (or pillow case to stuff with clothes)
- 1 small tarp
- rope for tying bed roll

CLOTHING:

- Brownie t-shirt (girls should travel to camp in it)
- 2 pairs of long pants
- 2 long sleeved shirts
- 3 changes of underwear
- 4 pairs of socks
- Warm pyjamas
- Warm sweater/sweatshirt
- Warm hat (toque)
- Gloves or mitts
- Rain gear (water-proof jacket & pants)
- Rain boots
- Outside shoes for dry weather
- Indoor shoes or slippers

OTHER:

- Flashlight & extra batteries
- Sunscreen
- Sit-upon
- Water bottle
- Toothbrush/paste, soap, and other toiletries
- Brush/comb
- Small towel & wash cloth
- Daypack (school sized backpack)
- Dishes (unbreakable plate, mug, bowl, fork, knife, spoon in a mesh bag)

OPTIONAL:

- 1 Small stuffed animal for bedtime
- Camera
- Book/quiet time activities
- Camp blanket

REMINDERS:

- We will be going outside rain or shine, so please make sure you have the appropriate clothing for the weather.
- Girls are expected to wear hats at all times when outside at camp.
- Remember “**a warm camper is a happy camper**” and that wool, fleece and synthetic materials are warmer than cotton for ANY clothing items!

Please ensure that ALL of your items are clearly labeled with names, especially sleeping bag bags!

EVALUATION FORM

Please share with us what you liked about this Camp to Go, and any things that we could improve on for next time! Thanks for your input, and Happy Camping!

WHAT DID YOU LIKE BEST?

WHAT WORKED/DIDN'T WORK FOR YOU?

WHAT COULD WE IMPROVE ON FOR NEXT TIME?

COMMENTS

Please return to:
BC Camping Committee
107-252 Esplanade Ave W,
North Vancouver, British Columbia V7M 0E9

or e-mail to:
bc-camping@girlguides.ca

